



# S5610 (STATIONARY) M5610 (MOBILE)

UP TO 550 HP (410 kW), 1750 LB-FT (2373 N•m)



## SPECIFICATIONS

RATINGS	Net Input Torque lb-ft (N•m)	Net Input Power hp (kW)	Turbine Torque lb-ft (N•m)	
<b>Straight-Thru Models</b>				
S5610	Winch, Auger	1750 (2373)	550 (410)	3120 (4230)
	Oil Field Equipment	1750 (2373)	550 (410)	3476 (4713)
M5610	Rear Dump Truck, Coal Hauler, Articulated Dump	1750 (2373)	550 (410)	3120 (4230)
	Oil Field, Crash Truck, Crane Carrier	1750 (2373)	550 (410)	3476 (4713)
	Agricultural Tractor	1485 (2013)	450 (335)	3120 (4230)
<b>Dropbox Models</b>				
S5610	Winch, Auger	1575 (2135)	500 (373)	3120 (4230)
	Oil Field Equipment	1575 (2135)	534 (398)	3476 (4713)
M5610	Rear Dump Truck, Coal Hauler, Articulated Dump	1575 (2135)	500 (373)	3120 (4230)
	Oil Field, Crash Truck, Crane Carrier	1575 (2135)	534 (398)	3476 (4713)

### ENGINE INTERFACE

Acceptable full-load engine governed speed	1900–2500 rpm
Minimum engine idle speed range (with transmission in Drive)	550 rpm

### MOUNTING

Direct	SAE No. 1 automatic flywheel housing with flexplate drive. Cradle mount using engine flywheel housing mounting pads and transmission rear cover mounting pads (or dropbox side pads, if applicable) with 0.625-11 inch series bolts
Remote	Side pads on transmission rear cover (or dropbox side pads, if applicable) plus front trunnion mount

### TORQUE CONVERTER

Type	Single stage, three element, polyphase	
	Stall Torque Ratio	Kp-Factor* at Stall
TC-580	2.89	62.2 (53.4)
TC-680 (with retarder )	2.17	53.2 (45.7)
TC-680 (without retarder)	2.08	54.6 (46.9)
TC-682	1.77	43.7 (37.5)
TC-683	1.85	35.1 (30.1)

\*Kp-Factor defines torque converter capacity. Kp = the ratio of converter pump speed [rpm] divided by the square root of the pump torque [lb-ft (N•m)]

### MECHANICAL RATIOS\*

Range	
First	4.00:1
Second	2.68:1
Third	2.01:1
Fourth	1.35:1
Fifth	1.00:1
Sixth	0.67:1
Reverse 1	- 5.15:1
Reverse 2	- 3.46:1
Ratio coverage	
Forward	5.97
Dropbox, if applicable	1.00:1

\*Gear ratios do not include torque converter multiplication.

### CONTROL SYSTEM

Description	Automatic electronic, manual electric, manual hydraulic
-------------	---

## OPTIONAL ENGINE-DRIVEN POWER TAKEOFF PROVISION

### Side mount

Location	5 o'clock position, as viewed from rear	
PTO drive gear rating	Intermittent	46 tooth drive gear, 200 hp (149 kW)
	Continuous	46 tooth drive gear, 125 hp (93 kW)

### Top mount

Location	12 o'clock position, as viewed from rear	
PTO drive gear rating	Intermittent	46 tooth drive gear, 200 hp (149 kW)
	Continuous	46 tooth drive gear, 125 hp (93 kW)

## SPEEDOMETER PROVISIONS

### Electronic

Description	LS-TTL signal, 39 pulses per output shaft revolution	
Location	Output signal from transmission ECU	

### Mechanical Drive (straight-thru)

Description	SAE "Heavy Duty" 5/32-inch; Ratio = 0.50:1	
Location	Transmission rear cover	

### Mechanical Drive (dropbox)

Description	SAE "Heavy Duty" 5/32-inch; Ratio = 1.00:1	
Location	Rear surface of dropbox module	

## OPTIONAL RETARDER PROVISION

Input	Integral, hydraulic	
Capacity	Torque	Power
	1500 lb-ft (2034 N•m)	600 hp (447 kW)

SIZE	Straight-Thru		Dropbox (with disconnects)
	Depth (below horizontal centerline)	17.0 in (432 mm)	
Length (direct mount) <sup>1,2</sup> Basic	43.2 in (1097 mm)		51.5 in (1308 mm)
	With retarder	46.6 in (1184 mm)	
Width (without filters) Basic	26.8 in (681 mm)		26.9 in (683 mm)
	With retarder	30.0 in (762 mm)	
Height Basic	31.0 in (787 mm)		40.7 in (1034 mm)
	With direct mount filters	35.5 in (902 mm)	
<b>Dry Weight</b>			
Basic model	2200 lb (998 kg)		2750 lb (1247 kg)
With top engine driven PTO drive gear	2230 lb (1012 kg)		2780 lb (1261 kg)
With park brake	2260 lb (1025 kg)		2810 lb (1274 kg)
With remote mount	2255 lb (1023 kg)		2805 lb (1272 kg)
With retarder	2365 lb (1073 kg)		2915 lb (1322 kg)

## OIL SYSTEM

Oil type	C-4, 15W40	
Capacity, excluding external circuits	18.0 gallons (68 liters)	
Dropbox	13.0 gallons (49 liters)	
<b>Main circuit oil filter</b>		
Standard	Manifold for full-flow, remote mounted, replaceable element	
Optional	Direct-mount full flow, replaceable elements (2)	
Cooler circuit oil filter (optional)	Replaceable element, remote-mounted	

<sup>1</sup> For remote mounting, add 10–11 inches (254–279 mm), depending on flange selection.

<sup>2</sup> Length is approximate from engine/converter mounting surface to face of typical output flange.

Today's engine and axle options have made specifying a truck more demanding. We can help. Whether you're looking for enhanced fuel economy, increased productivity or high performance, we have the tools to help you select an Allison Transmission that will match your specific application needs. Call 1-800-252-5ATD. You'll get the right transmission for your job.

## DESIGN FEATURES

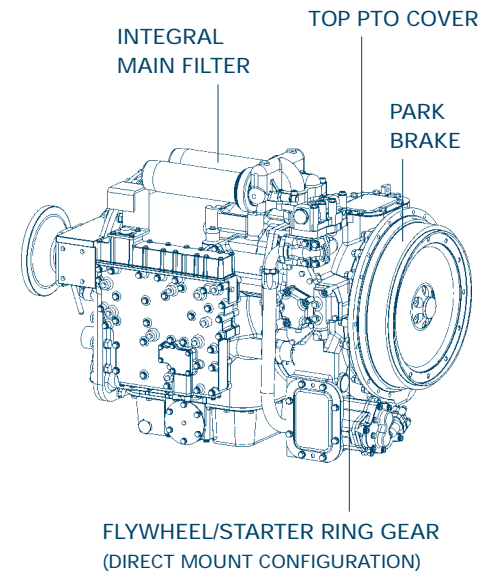

P.O. BOX 894, SPEED CODE PF38  
 INDIANAPOLIS, INDIANA 46206-0894  
 1-800-252-5ATD  
 www.allisontransmission.com

INFORMATION AND SPECIFICATIONS SUBJECT TO CHANGE WITHOUT NOTICE OR OBLIGATION. SA3028EN (2001/06) LITHO IN U.S.A.

