



S6610 (STATIONARY)  
M6610 (MOBILE)

UP TO 850 HP (634 kW), 2300 LB-FT (3118 N•m)



SPECIFICATIONS

	RATINGS	Net Input Torque	Net Input Power	Turbine Torque
		lb-ft (N•m)	hp (kW)	lb-ft (N•m)
S6610	Coal Auger, Hoist, Winch	2270 (3078)	710 (529)	3790 (5139)
	Oil Well Workover, Cementing, Fracturing	2300 (3118)	850 (634)	4000 (5423)
M6610	Rear Dump Truck, Coal Hauler, Articulated Dump	2270 (3078)	710 (529)	3790 (5139)
	Agricultural Tractor	1860 (2250)	650 (485)	3340 (4528)
	Oil Field Service Rig, Oil Field Pumper	2300 (3118)	850 (634)	4000 (5423)

ENGINE INTERFACE

Acceptable full-load engine governed speed	1900–2500 rpm
Minimum engine idle speed range (with transmission in Drive)	550 rpm

MOUNTING

Direct	SAE No.1 automatic flywheel housing with flexplate drive. Cradle mount using engine flywheel housing mounting pads and transmission rear cover mounting pads with 0.625-11 inch series bolts
Remote	Side pads on transmission rear cover, plus front trunnion mount

TORQUE CONVERTER

Type	Single stage, three element, polyphase	
	Stall Torque Ratio	Kp-Factor* at Stall
TC-680 (with retarder )	2.17	53.2 (45.7)
TC-680 (without retarder)	2.08	54.6 (46.9)
TC-682	1.77	43.7 (37.5)
TC-683	1.85	35.1 (30.1)

\*Kp-Factor defines torque converter capacity. Kp = the ratio of converter pump speed [rpm] divided by the square root of the pump torque [lb-ft (N•m)]

MECHANICAL RATIOS\*

Range	
First	4.00:1
Second	2.68:1
Third	2.01:1
Fourth	1.35:1
Fifth	1.00:1
Sixth	0.67:1
Reverse 1	- 5.15:1
Reverse 2	- 3.46:1
Ratio coverage Forward	5.97

\*Gear ratios do not include torque converter multiplication.

CONTROL SYSTEM

Description	Automatic electronic, manual electric, manual hydraulic
-------------	---

OPTIONAL ENGINE-DRIVEN POWER TAKEOFF PROVISION

Side mount		
Location		5 o'clock position, as viewed from rear
PTO drive gear rating	Intermittent	46 tooth drive gear, 200 hp (149 kW)
	Continuous	46 tooth drive gear, 125 hp (93 kW)
Top mount		
Location		12 o'clock position, as viewed from rear
PTO drive gear rating	Intermittent	46 tooth drive gear, 200 hp (149 kW)
	Continuous	46 tooth drive gear, 125 hp (93 kW)

**SPEEDOMETER PROVISIONS**

**Electronic**

Description	LS-TTL signal, 39 pulses per output shaft revolution
Location	Output signal from transmission ECU

**Mechanical Drive**

Description	SAE "Heavy Duty" 5/32-inch; Ratio = 0.50:1
Location	Transmission rear cover

**OPTIONAL RETARDER PROVISION**

Input	Integral, hydraulic	
Capacity	Torque	Power
	1500 lb-ft (2034 N•m)	600 hp (447 kW)

**SIZE**

Depth (below horizontal centerline)	20.1 in (511 mm)	
	Basic	With Retarder
Length (direct mount) <sup>1,2</sup>	43.2 in (1097 mm)	46.6 in (1184 mm)
Width	26.8 in (681 mm)	30.0 in (762 mm)
	Height	Dry Weight
Basic model	31.0 in (787 mm)	2200 lb (998 kg)
With direct mount filters	35.5 in (902 mm)	2200 lb (998 kg)
With top engine-driven PTO drive gear		2230 lb (1012 kg)
With park brake (12" x 5")		2260 lb (1025 kg)
With remote mount		2255 lb (1023 kg)
With retarder		2365 lb (1073 kg)

**OIL SYSTEM**

Oil type	C-4, 15W40
Capacity, excluding external circuits	18.0 gallons (68 liters)
Main circuit oil filter	
Standard	Manifold for full-flow, remote mounted, replaceable element
Optional	Direct-mount full flow, replaceable elements (2)
Cooler circuit oil filter (optional)	Replaceable element, remote-mounted

1 For remote mounting, add 10–11 inches (254–279 mm), depending on flange selection.  
 2 Length is approximate from engine/converter mounting surface to face of typical output flange.

Today's engine and axle options have made specifying a truck more demanding. We can help. Whether you're looking for enhanced fuel economy, increased productivity or high performance, we have the tools to help you select an Allison Transmission that will match your specific application needs. Call 1-800-252-5ATD. You'll get the right transmission for your job.

**DESIGN FEATURES**

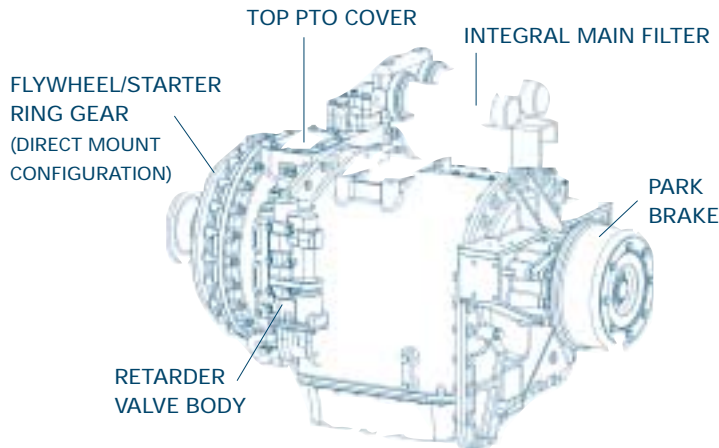

P.O. BOX 894, SPEED CODE PF3  
 INDIANAPOLIS, INDIANA 46206-0894  
 1-800-252-5ATD

