



DP8962 (STATIONARY)
DP8963 (MOBILE)

UP TO 1104 HP (823 kW), 3300 LB-FT (4474 N•m)



SPECIFICATIONS

RATINGS	Net Input Torque lb-ft (N•m)	Net Input Power hp (kW)	Turbine Torque lb-ft (N•m)
Rear Dump Truck, Coal Hauler, Auger	3300 (4474)	975 (727)	5640 (7647)
Oil Field Pumper, Oil Field Service Rig	3300 (4474)	1104 (823)	5966 (8089)

ENGINE INTERFACE

Acceptable full-load engine governed speed	1800–2300 rpm
Minimum engine idle speed range (with transmission in Drive)	550 rpm

MOUNTING

Direct	SAE No. 0 automatic flywheel housing with flexplate drive. Cradle mount using engine flywheel housing mounting pads and transmission rear cover mounting pads with 0.625-11 inch series bolts
Remote	Side pads on transmission rear cover, plus front trunnion mount

TORQUE CONVERTER

Type	Single stage, three element, polyphase	
	Stall Torque Ratio	Kp-Factor* at Stall
TC-840	2.26	43.2 (37.1)
TC-860	2.33	40.7 (35.0)
TC-880	2.20	36.9 (31.7)
TC-890	1.86	32.6 (28.0)
TC-1070	1.68	28.5 (24.5)

Includes standard integral damper which is operational in lockup

*Kp-Factor defines torque converter capacity. Kp = the ratio of converter pump speed [rpm] divided by the square root of the pump torque [lb-ft (N•m)]

MECHANICAL RATIOS*

Range	
First	4.24:1
Second	2.32:1
Third	1.69:1
Fourth	1.31:1
Fifth	1.00:1
Sixth	0.73:1
Reverse	- 5.75:1
Ratio coverage	
Forward	5.81

*Gear ratios do not include torque converter multiplication.

CONTROL SYSTEM

Description	Automatic electronic, manual electric
-------------	---------------------------------------

OPTIONAL ENGINE-DRIVEN POWER TAKEOFF PROVISION

Side mount		
Location		5 o'clock position, as viewed from rear
PTO drive gear rating	Intermittent	59 tooth drive gear, 400 hp (298 kW)
	Continuous	59 tooth drive gear, 300 hp (224 kW)
Top mount		
Location		12 o'clock position, as viewed from rear
PTO drive gear rating	Intermittent	59 tooth drive gear, 400 hp (298 kW)
	Continuous	59 tooth drive gear, 300 hp (224 kW)

SPEEDOMETER PROVISIONS

Description	Mechanical Drive, SAE "Heavy Duty" 5/32-inch; Ratio = 1.00:1
Location	Transmission rear cover

OPTIONAL RETARDER PROVISION

Input	Integral, hydraulic	
Capacity	Torque	Power
	3451 lb-ft (4679 N•m)	1380 hp (1029 kW)

SIZE

Length (direct mount) ^{1,2}	57.0 in (1448 mm)	
Width	45.0 in (1143 mm)	
Depth (below horizontal centerline)	20.9 in (531 mm)	
	Height	Dry Weight
Basic model with retarder	35.3 in (897 mm)	3700 lbs (1678 kg)
With direct mount filters	39.9 in (1013 mm)	3700 lbs (1678 kg)
With top engine driven PTO drive gear		3730 lbs (1692 kg)
With park brake		3850 lbs (1746 kg)
With remote mount		3780 lbs (1714 kg)

OIL SYSTEM

Oil type	C-4, 15W40
Capacity, excluding external circuits	21.0 gallons (79 liters)
Main circuit oil filter	
Standard	Manifold for full-flow, remote mounted, replaceable element
Optional	Direct-mount full flow, replaceable elements (2)
Cooler circuit oil filter (optional)	Replaceable element, remote-mounted

¹ For remote mounting, add 11 inches (279 mm).

² Length is approximate from engine/converter mounting surface to face of typical output flange.

Today's engine and axle options have made specifying a truck more demanding. We can help. Whether you're looking for enhanced fuel economy, increased productivity or high performance, we have the tools to help you select an Allison Transmission that will match your specific application needs. Call 1-800-252-5ATD. You'll get the right transmission for your job.

DESIGN FEATURES

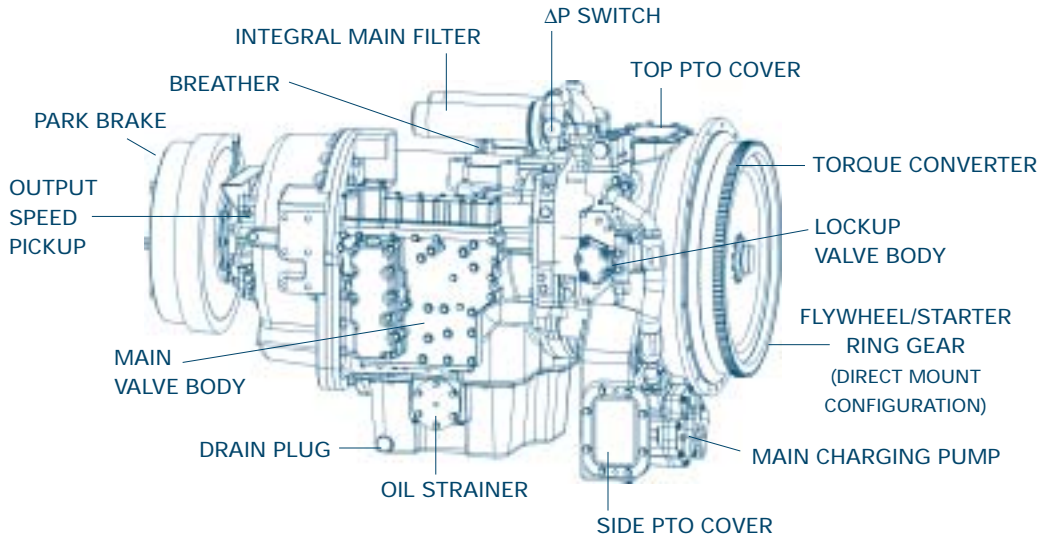

P.O. BOX 894, SPEED CODE PF3
 INDIANAPOLIS, INDIANA 46206-0894
 1-800-252-5ATD

