

1000 Series

International Series 1000

RATINGS

Model ⁽¹⁾		Gross Input Torque ⁽²⁾ N•m	Gross Input Power ⁽²⁾ kW (hp)	Gross Input Torque ⁽²⁾⁽³⁾ N•m	Gross Input Power ⁽²⁾⁽³⁾ kW (hp)	GVW kg	GCW kg
1000	General	780	224 (300)	895	254 (340)	9000	11,800
	Refuse, On-Highway	746	224 (300)	766	224 (300)	7500	7500
	Transit Bus, Shuttle Bus, Coach, Non-North America School Bus	705	149 (200)	750	164 (220)	7500	7500
1000 MH	Motorhome	746	224 (300)	895	254 (340)	10,000	11,800
1000 SP	Specialty Vehicles	CONTACT YOUR ALLISON REPRESENTATIVE FOR DETAILS					

(1). Models including vocational designations (ie: ORS, OFS, SP, MH) are for global markets. All other models within this document are targeted for outside North American markets only.
 (2). Gross ratings as defined by ISO 1585 or SAE J1995. (3). Shift Energy Management (SEM) engine controls and torque limiting are required to obtain this rating.

DRIVETRAIN INTERFACES

Acceptable full-load engine governed speed	2200 – 3800* rpm
Acceptable engine idle speed range (with transmission in Drive)	500 – 820 rpm
Maximum output shaft speed at 105 km/hr	5000 rpm

* Engines with full load governed speed greater than 3800 rpm require Application Engineering review

MOUNTING

To Engine SAE No.3, SAE No.2

TORQUE CONVERTER

Type One stage, three element, polyphase.
Includes standard integral damper which is operational in lockup.

Model	Stall Torque Ratio
TC-210	2.05
TC-211	1.91
TC-221	1.73
TC-222	1.58

MECHANICAL RATIOS (Gear ratios do not include torque converter multiplication)

Range

First	3.10 : 1
Second	1.81 : 1
Third	1.41 : 1
Fourth	1.00 : 1
Fifth	0.71 : 1
Sixth	0.61 : 1
Reverse	-4.49 : 1

CONTROL SYSTEM

Description Allison 5th Generation Electronic Controls with closed loop adaptive shifts

Shift Sequences [C = Converter mode (lockup clutch disengaged); L = Lockup mode (lockup clutch engaged)]

Option 1: 1C-[1L]-2C-2L-3L-4L-5L

Option 2: 1C-[1L]-2C-2L-3L-4L-5L-6L

Driver-to-Transmission Interface Cab-mounted shift selector

Communication Protocol - Engine/Vehicle Systems Interface SAE J1939, IESCAN, PT-CAN

PHYSICAL DESCRIPTION

	Installation Length*	Dry Weight	Depth below transmission centerline	
			With Shallow Oil Sump	With Deep Oil Sump
SAE No.3	729 mm	150 kg	272 mm	285 mm
SAE No.2	739 mm	150 kg	272 mm	285 mm

*Approximate length from engine housing to output flange (depending on output flange type)

TURBINE-DRIVEN POWER TAKE-OFF PROVISION

PTO drive	Torque converter turbine-driven spur gear
PTO mounting pads	Six-bolt, 3 o'clock and 9 o'clock positions (as viewed from rear)
PTO drive gear rating (continuous operation)	Using one PTO: 339 N•m Total using two PTO's: 271 N•m
PTO drive gear ratio	1.00 x turbine speed
PTO drive gear	64 tooth

PARK PAWL*

*Excluding refuse vocation

OIL SYSTEM

Allison approved fluids: TES 295 and TES 389

Capacity, excluding external circuits

With Deep Oil Pan	14 litres
With Shallow Oil Pan	12 litres
Spin on canister filter	Standard

SPEEDOMETER PROVISION

Description	Non-zero-crossing square wave
	8, 16 or 40 pulses per revolution of transmission output shaft
Location	Electronic output from TCM

TACHOGRAPH PROVISION

Tone wheel	6-tooth
Mounting	M18 x 1.5 metric thread
Location	Transmission rear cover

1000 Series

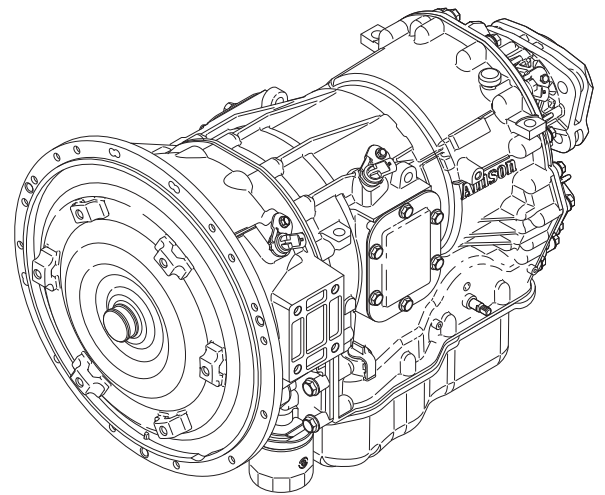
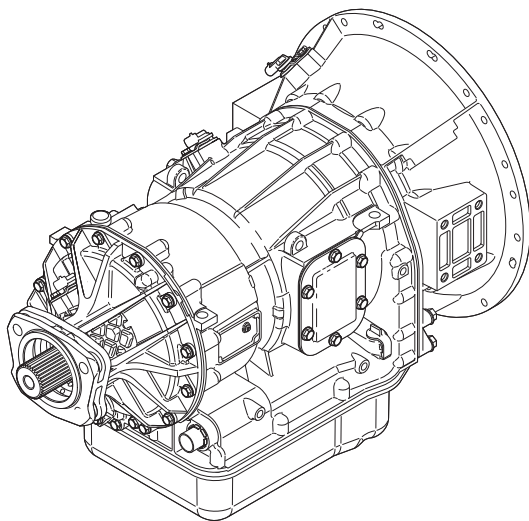

Transdiesel Australia Pty Ltd
 77 McKellar Way, Epping, Victoria, Australia 3076
 ph: (03) 9305 0800
 www.transdiesel.com.au

